

Caratteristiche: BASE VULCANIZZATA Ø 100, STELO SNODATO 10°

Features: VULCANIZED BASE Ø 100, 10° ARTICULATED STEM

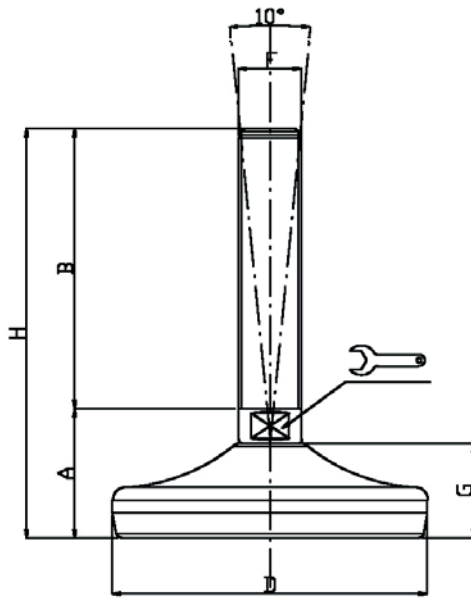

CODICE - CODE	descrizione description	DIMENSIONI PRINCIPALI - MAIN DIMENSIONS							CARICO STATICO STATIC LOAD NEWTON
		A	B	D	CH	F	G	H	
25100	M16X75	42	75	Ø100	13	M16	30	117	15000
25102	M16X100	42	100	Ø100	13	M16	30	142	15000
25104	M16X125	42	125	Ø100	13	M16	30	167	15000
25106	M16X150	42	150	Ø100	13	M16	30	192	15000
25108	M16X175	42	175	Ø100	13	M16	30	217	15000
25110	M16X200	42	200	Ø100	13	M16	30	242	15000
25120	M20X75	42	75	Ø100	17	M20	30	117	15000
25122	M20X100	42	100	Ø100	17	M20	30	142	15000
25124	M20X125	42	125	Ø100	17	M20	30	167	15000
25126	M20X150	42	150	Ø100	17	M20	30	192	15000
25128	M20X175	42	175	Ø100	17	M20	30	217	15000
25130	M20X200	42	200	Ø100	17	M20	30	242	15000
25132	M20X225	42	225	Ø100	17	M20	30	267	15000
25134	M20X250	42	250	Ø100	17	M20	30	292	15000
25150	M24X100	44	100	Ø100	20	M24	30	144	15000
25152	M24X125	44	125	Ø100	20	M24	30	169	15000
* 25154	M24X150	44	150	Ø100	20	M24	30	194	15000
* 25156	M24X175	44	175	Ø100	20	M24	30	219	15000
* 25158	M24X200	44	200	Ø100	20	M24	30	244	15000
25160	M24X225	44	225	Ø100	20	M24	30	269	15000
25162	M24X250	44	250	Ø100	20	M24	30	294	15000
25180	M30X100	44	100	Ø100	26	M30	30	144	15000
25182	M30X125	44	125	Ø100	26	M30	30	169	15000
* 25184	M30X150	44	150	Ø100	26	M30	30	194	15000
25186	M30X175	44	175	Ø100	26	M30	30	219	15000
* 25188	M30X200	44	200	Ø100	26	M30	30	244	15000
25200	M30X225	44	225	Ø100	26	M30	30	269	15000
25202	M30X250	44	250	Ø100	26	M30	30	294	15000

* Disponibile con Filettatura a passo fine. Aggiungere "/P2" al codice
Available with Thin pitch thread. Please, add "/P2" to the code

• I valori dei carichi sopra riportati sono calcolati in condizioni statiche alla metà della lunghezza dello stelo filettato. Qualora s'intendesse utilizzare i supporti in presenza di vibrazioni o carichi in movimento, tali valori dovranno essere adeguatamente ridotti. Per ulteriori chiarimenti consultare il nostro ufficio tecnico. Ogni nostra responsabilità decade in caso di manomissioni o modifiche dei componenti.

• Load values above mentioned have to be considered referring to static conditions calculated at the half of the screw length. In conditions of vibrations or in presence of dynamic loads these values should be reduced. For further information consult our technical office. We cannot accept responsibility for mounts that have been tampered or modified