

## Piede in Acciaio Zincato

**Caratteristiche: BASE Ø 65 CON 1-2 FORI,**

**STELO SNODATO 8° O FISSO CON DADO**

**Features: BASE Ø 65 WITH 1-2 BORES, 8° ARTICULATED STEM OR FIX BY BOTTOM LOCKING NUT**

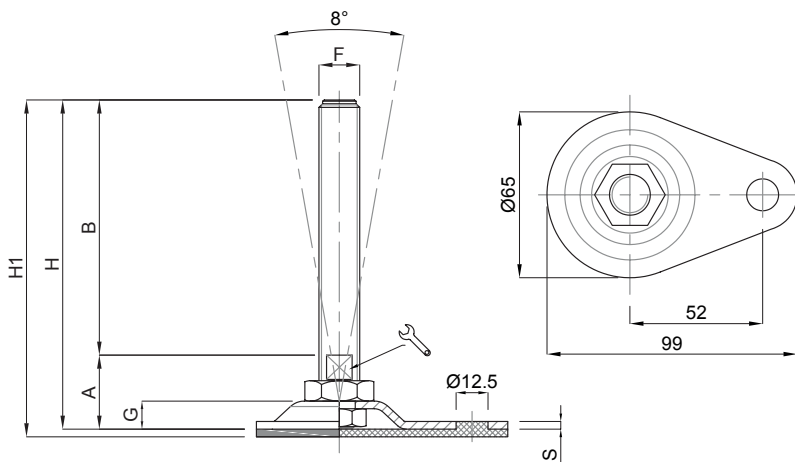

CODICE - CODE		descrizione description	DIMENSIONI PRINCIPALI - MAIN DIMENSIONS								CARICO STATICO STATIC LOAD NEWTON
Standard Standard	Antiscivolo Antislip		S	B	A	🔧	F	G	H	H1	
15754	15754/G	M12x100	3	100	28	10	M12	11	128	131	15000
15756	15756/G	M12x150	3	150	28	10	M12	11	178	181	15000
15758	15758/G	M16x100	3	100	29	13	M16	11	129	132	20000
15760	15760/G	M16x150	3	150	29	13	M16	11	179	182	20000
15762	15762/G	M16x200	3	200	29	13	M16	11	229	232	20000
15764	15764/G	M20x150	3	150	32	17	M20	11	182	185	20000
15766	15766/G	M20x200	3	200	32	17	M20	11	232	235	20000

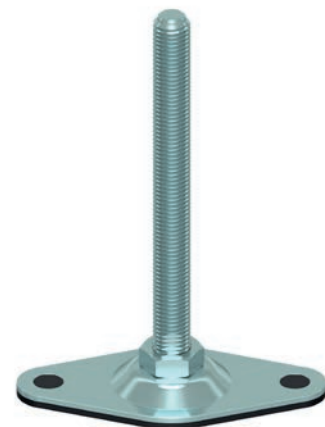
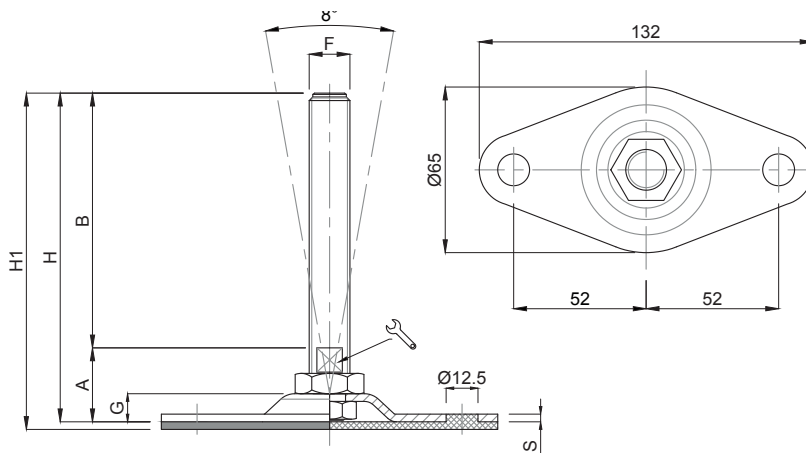

CODICE - CODE		descrizione description	DIMENSIONI PRINCIPALI - MAIN DIMENSIONS								CARICO STATICO STATIC LOAD NEWTON
Standard Standard	Antiscivolo Antislip		S	B	A	🔧	F	G	H	H1	
15768	15768/G	M12X100	3	100	28	10	M12	11	128	131	15000
15770	15770/G	M12X150	3	150	28	10	M12	11	178	181	15000
15772	15772/G	M16X100	3	100	29	13	M16	11	129	132	20000
15774	15774/G	M16X150	3	150	29	13	M16	11	179	182	20000
15776	15776/G	M16X200	3	200	29	13	M16	11	229	232	20000
15778	15778/G	M20X150	3	150	32	17	M20	11	182	185	20000
15780	15780/G	M20x200	3	200	32	17	M20	11	232	235	20000

• Base stampata in acciaio zincato FE. Stelo acciaio zincato FE. Su richiesta l'elemento di livellamento viene fornito con dado in acciaio

• Material: pressed base in galvanized steel. Galvanized steel screw. The levelling element could be supplied with steel nut.