

CODICE - CODE	descrizione - description
<b>60080L</b>	<b>CERNIERA PER PORTE LUCIDA 40X40</b>
<b>60080S</b>	<b>CERNIERA PER PORTE SABBBIATA 40X40</b>

- Materiale: acciaio inox AISI 304 con fissaggio interno tramite 2 fori M6; perno M8
- Material stainless steel 1.4301 hinge with inside fixing system through holes M6; screw M8  
L= polished surface finishing S= sandblasted surface finishing

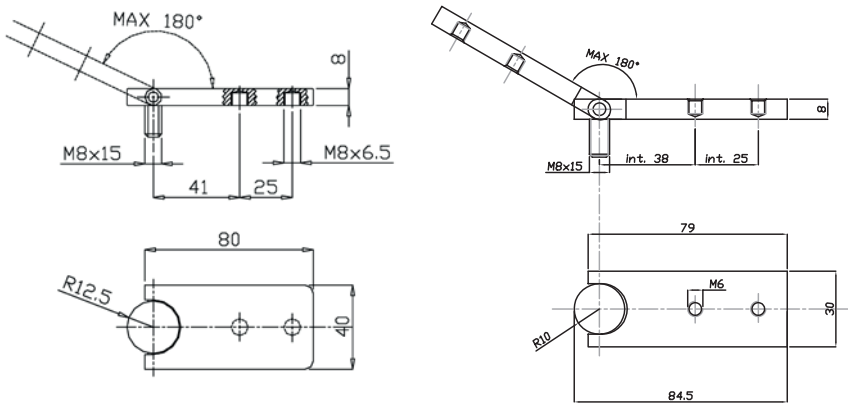

CODICE - CODE	descrizione - description
<b>60085L</b>	<b>CERNIERA PER PORTE LUCIDA 30X80</b>
<b>60085S</b>	<b>CERNIERA PER PORTE SABBBIATA 30X80</b>
<b>60090L</b>	<b>CERNIERA PER PORTE LUCIDA 40X80</b>
<b>60090S</b>	<b>CERNIERA PER PORTE SABBBIATA 40X80</b>

- Materiale: acciaio inox AISI 304 con fissaggio interno tramite 2 fori M8; perno M8
- Material stainless steel 1.4301 Hinge with inside fixing system with two holes M8; screw M8  
L= polished surface finishing S= sandblasted surface finishing