

## Piedini PA/Zincato

MINI

Martin  
Levelling Components

Caratteristiche: BASE ZIGRINATA Ø 20/25/28/32/35, STELO FISSO

Features: KNURLED BASE Ø 20/25/28/32/35, FIX STEM

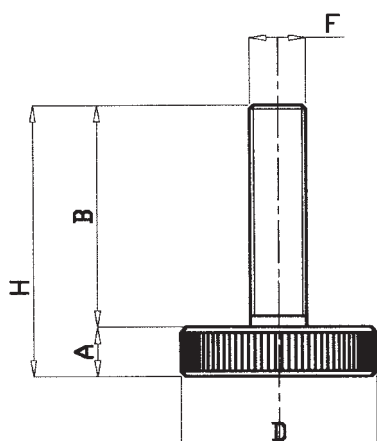

CODICE - CODE	descrizione - description	DIMENSIONI PRINCIPALI - MAIN DIMENSIONS					CARICO STATICO STATIC LOAD NEWTON
		B	D	F	A	H	
30400	M6x17	17	Ø 25	M6	7	24	1500
30410	M8x25	25	Ø 25	M8	7	32	1500
30420	M10x35	35	Ø 25	M10	7	42	1500
30430	M8x25	25	Ø 35	M8	9	34	2500
30440	M10x25	25	Ø 35	M10	9	34	2500
30450	M10x30	30	Ø 35	M10	9	39	2500
30460	M10x35	35	Ø 35	M10	9	44	2500
30470	M10x40	40	Ø 35	M10	9	49	2500

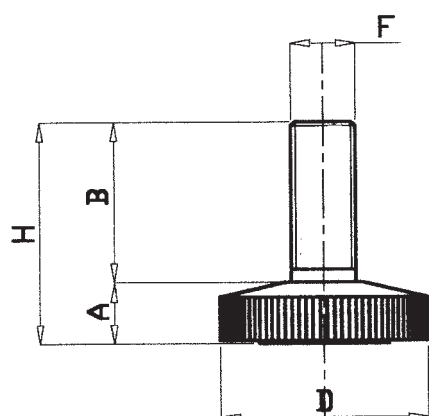

CODICE - CODE	descrizione - description	DIMENSIONI PRINCIPALI - MAIN DIMENSIONS					CARICO STATICO STATIC LOAD NEWTON
		B	D	F	A	H	
30300	M6x20	20	Ø 20	M6	6,5	26,5	1500
30310	M8x22	22	Ø 28	M8	8	30	2000
30320	M10x25	25	Ø 32	M10	9,5	34,5	2500

• Base in poliammide, stelo acciaio zincato

• Polyamide base, galvanized steel screw

MINI