

Piede in Inox

STAMPATI

Martin
Levelling Components

Caratteristiche: BASE Ø 65, STELO SNODATO 8°

Features: BASE Ø 65, 8° ARTICULATED STEM

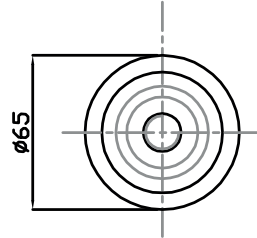
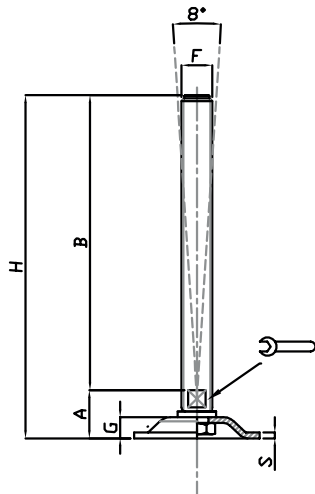

| CODICE - CODE | descrizione description | DIMENSIONI PRINCIPALI - MAIN DIMENSIONS | | | | | | | CARICO STATICO STATIC LOAD NEWTON |
|---------------|----------------------------|---|-----|-------|---|-----|----|--------|---|
| | | S | B | A |  | F | G | H | |
| 15874 | M12X100 | 3 | 100 | 22,50 | 10 | M12 | 11 | 122,50 | 15000 |
| 15876 | M12X150 | 3 | 150 | 22,50 | 10 | M12 | 11 | 172,50 | 15000 |
| 15878 | M16X100 | 3 | 100 | 22,50 | 13 | M16 | 11 | 122,50 | 20000 |
| 15880 | M16X150 | 3 | 150 | 22,50 | 13 | M16 | 11 | 172,50 | 20000 |
| 15882 | M16X200 | 3 | 200 | 22,50 | 13 | M16 | 11 | 222,50 | 20000 |
| 15884 | M20X150 | 3 | 150 | 24,50 | 17 | M20 | 11 | 199 | 20000 |
| 15886 | M20X200 | 3 | 200 | 24,50 | 17 | M20 | 11 | 224,50 | 20000 |

Caratteristiche: BASE 100X100 CON 4 FORI, STELO SNODATO 8° O FISSO CON DADO

Features: BASE 100X100 WITH 4 BORES, 8° ARTICULATED STEM OR FIX BY BOTTOM LOCKING NUT

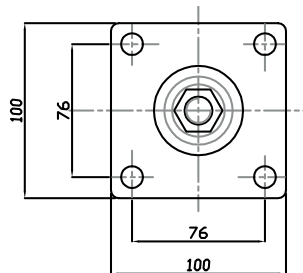
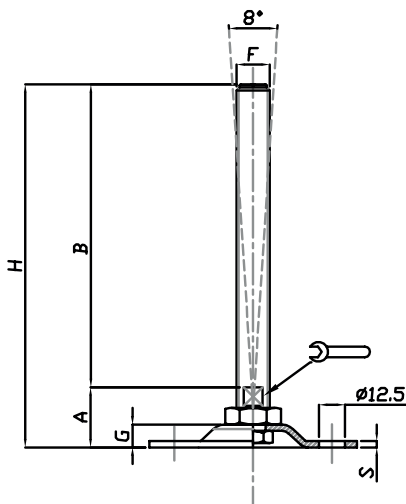

| CODICE - CODE | descrizione description | DIMENSIONI PRINCIPALI - MAIN DIMENSIONS | | | | | | | CARICO STATICO STATIC LOAD NEWTON |
|---------------|----------------------------|---|-----|----|---|-----|----|-----|---|
| | | S | B | A |  | F | G | H | |
| 15862 | M16x150 | 3 | 150 | 29 | 13 | M16 | 11 | 179 | 20000 |
| 15864 | M16x200 | 3 | 200 | 29 | 13 | M16 | 11 | 229 | 20000 |
| 15866 | M20x150 | 3 | 150 | 32 | 17 | M20 | 11 | 182 | 25000 |
| 15868 | M20x200 | 3 | 200 | 32 | 17 | M20 | 11 | 232 | 25000 |
| 15870 | M24x150 | 3 | 150 | 32 | 20 | M24 | 11 | 182 | 30000 |
| 15872 | M24x200 | 3 | 200 | 32 | 20 | M24 | 11 | 232 | 30000 |

• Base stampata in acciaio inox AISI 304. Stelo acciaio inox AISI 304. Su richiesta l'elemento di livellamento viene fornito con dado in acciaio

• Material: stainless steel base 1.4301. Stainless steel screw 1.4301. The levelling element could be supplied with steel nut.

STAMPATI