

Hohlschraube, TYP X 10032378

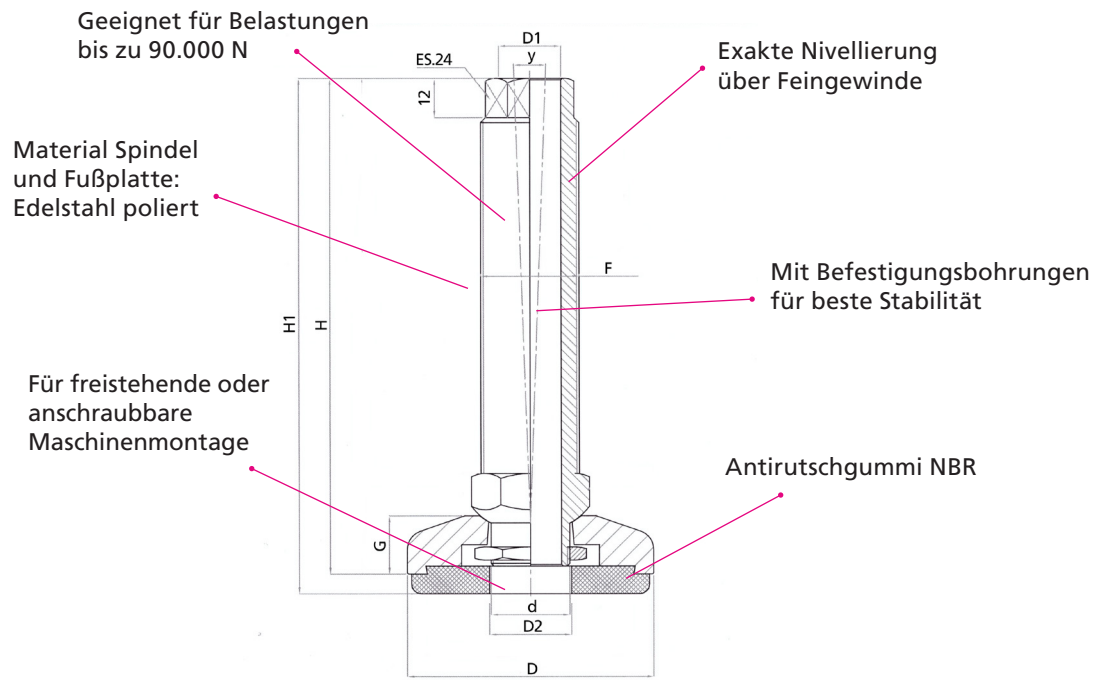

Bestell-Nr:	Typ:	D	D1	D2	d	F	G	H	H1	y	Belastbarkeit N
4061408115327	45812618/SS150T	75	19	25	M24 x 1.5	M30 x 1.5	18	152	158	4°	90.000
4061408113309	45812618/SS160T	120	17	23	M22	M30 x 1.5	18	1128	136	5°	90.000